

Basic Principles of Motor Controls

Unit 1—Introduction

This unit discusses the basic concepts of motor control, including “motor control language” and the types of wiring diagrams used.

Motor Control Circuits

Motor control circuits are an effective way to reduce cost by using smaller wire and reduced-amperage devices to control a motor. Imagine trying to wire a pushbutton station for a 100A motor using 3 AWG conductors. Many smaller motors use the same size conductors for both control and power circuits, but as the horsepower increases it becomes impractical to do so, **Figure 1-1**. Motor control circuits are often connected to lower voltages than the motor they control to make it safer for operators and maintenance personnel. A motor control circuit, for the most part, is simply a switch (or group of switches) and a motor. If you keep the word “switch” in mind, it helps keep the intimidating subject of “motor control” in its proper context. For example, the following can be considered motor controls:

A time clock that operates a pool or sprinkler pump is nothing more than an automatic switch. At a preset time, a set of contacts open or close (turn off or on).

Figure 1-2

An automatic garage door opener uses a radio signal to operate a switch that activates a garage door in much

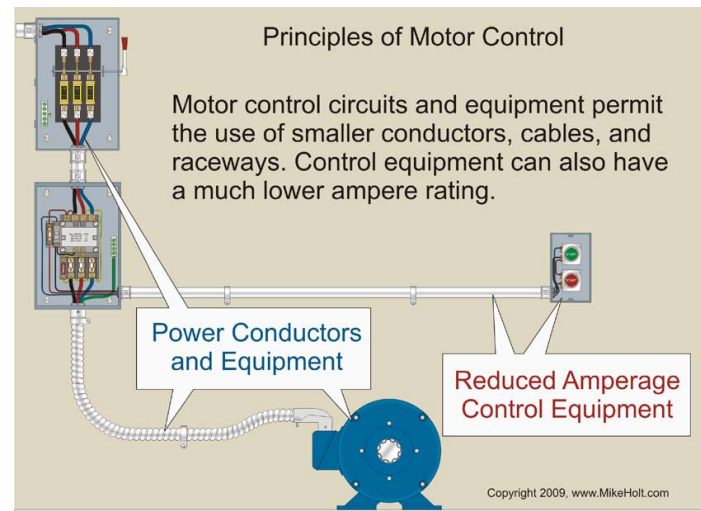

Figure 1-1

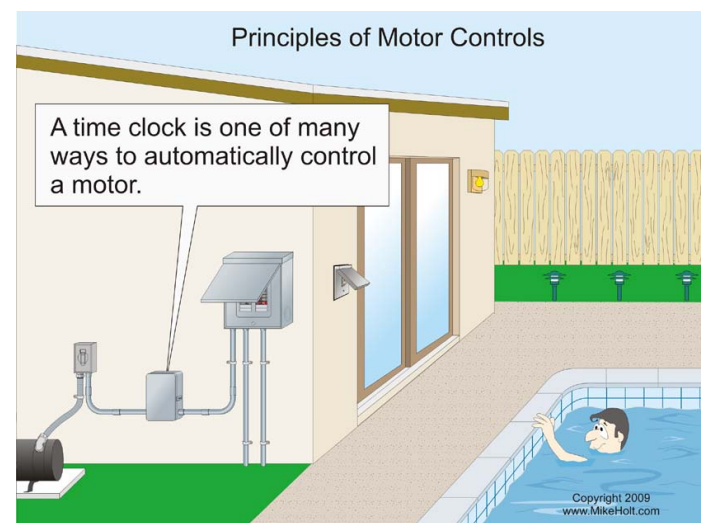

Figure 1-2

the same manner as a typical “up-down” pushbutton station.

Many motors are controlled by computerized control systems, solid-state logic controls, or programmable logic controllers (PLCs). The fundamentals of control systems still apply. The PLC controls an external output based on the logic of a control program, and that output controls the motor or groups of motors by using a magnetic starter, and in some cases additional relays. PLCs and other solid-state control devices were originally invented to provide less expensive replacements for older automated systems that used large numbers of relays and mechanical timers. In some cases, a single PLC can replace thousands of relays resulting in less expensive wiring systems that offer greater flexibility in control designs.

Author’s Comments:

- In industrial processes, the control of pressure, flow, speed, temperature, and other items are essential for efficient productivity and safety. Devices such as solid-state sensors, static controls, solid-state relays, and programmable controls can provide very precise control for an industrial process.
- Although the subject of solid-state controls isn’t covered in detail in this textbook, the concepts are very similar to other motor controls in that they essentially use switches to control motors.
- Many experts agree that the best way to learn about motor controls is to start with the standard control methods covered in this textbook. This statement also applies when electronic controls are the subject being studied.

Many control circuits include motor overload protection devices. Traditional overload (OL) protectors operate on the relationship between heat and current. As current increases, heat increases. If an overload device is rated 10A, and the current exceeds that rating, the OL

device will operate to open the circuit because of the increased heat caused by the current running through it. A magnetic starter or other motor controllers may include overload devices, or they may be an integral part of the motor, particularly with small motors.

Author’s Comment: Short circuits and ground faults aren’t considered overloads.

There are two basic designs of motor control equipment, NEMA and IEC.

NEMA (National Electrical Manufacturers Association). NEMA is a trade association for manufacturers of electrical equipment and supplies. NEMA standards specify motor horsepower (hp) ratings, speeds, motor frame sizes and dimensions, motor torques, motor starter size ratings, and enclosure specifications.

NEMA-rated products are typically heavy duty, can be used in a broad range of applications, and some starters can be maintained and repaired. For these reasons, they’re often more expensive than IEC motor starters. NEMA-rated motors and motor controllers are the type most commonly used in North America.

IEC (International Electrotechnical Commission). IEC is an international standards organization. IEC motor starters are often less expensive, smaller in size, are tailored for specific motor performance requirements, and the selection of the right starter for each application is very important. IEC-rated motor controllers are widely used in Europe and Asia.

1.1 Motor Control Language

Electrical symbols, words, and line diagrams provide the information necessary to understand the operation of motor control circuits. Used together, they create a

type of motor control “language” that’s used to transfer information and ideas quickly and efficiently.

The symbols in motor control schematics represent devices, power conductors, control conductors, conductor connections and terminals, and sometimes the motor itself.

The words, phrases, and abbreviations in a schematic are generally accepted terms that represent functions, describe actions, and list sequences of operation.

In many cases, the symbols and words have a similarity to the items they represent. The basic types of schematics are shown in **Figure 1–3**. Parts A, B, and C of that figure illustrate three different methods of representing the same control circuit.

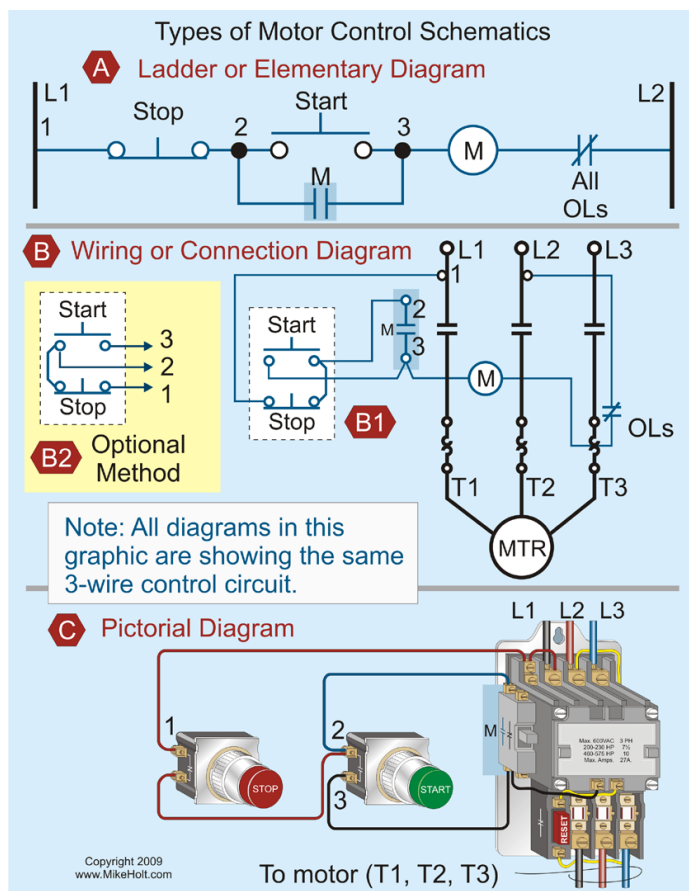

Figure 1–3

(1) Ladder Diagrams (Figure 1–4)

Ladder diagrams are also called “line diagrams” or “elementary diagrams.” They’re used to represent the function of the control circuit and the associated devices, but don’t show the components of the control circuit in their actual positions. As control circuits become more complex, a ladder diagram can be less complicated to read than a wiring or connection diagram. For example, in **Figure 1-4**, notice the set of contacts marked M under the start pushbutton. The M contacts marked 2 and 3 are actually located in the motor starter fairly close to the coil, as shown in **Figure 1–3B**, and the normal physical appearance of these contacts often look as shown in **Figure 1–3C**. (Notice that all three examples of the M contacts are shown with a blue background in **Figure 1–3**.)

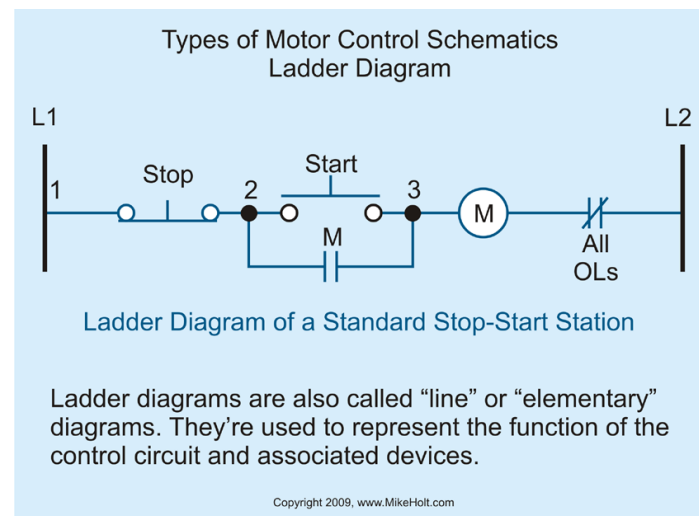

Figure 1–4

The ladder diagrams in **Figures 1–4 and 1–5** illustrates electrical function, showing the M contacts in parallel with the start pushbutton to form what’s called a “holding circuit.” The physical location of the M contacts isn’t shown in the ladder diagram.

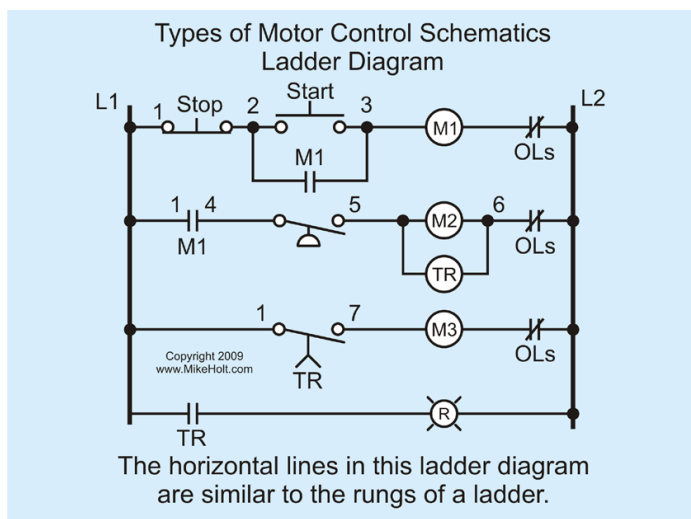

Figure 1-5

Figure 1-5 shows a more complicated version of a ladder diagram. Notice that the horizontal lines in this control circuit are similar to the rungs of a ladder.

Author's Comment: An important point to remember is that schematics show motors and control equipment in the resting, or off state (sometimes called the “shelf” state). Part of the difficulty, when first learning about motor controls, is in understanding how the different components of the control circuit interrelate during the operation of the controls.

(2) Connection Diagrams (Figure 1-6)

Connection diagrams, or wiring diagrams, show the components of the control circuit in a semblance of their actual physical locations. The start-stop pushbutton station is shown more as an actual device in the control circuit wired to a set of contacts marked 2 and 3. In Figure 1-4, the wires on each side of the M contacts trace back to points 2 and 3 on either side of the start pushbutton. The contacts marked M in Figure 1-4 are the same contacts as those marked 2 and 3 in Figure 1-6.

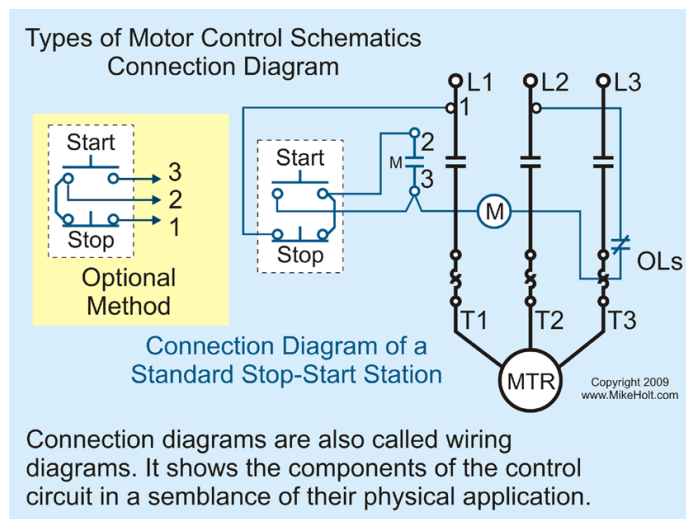

Figure 1-6

Different manufacturers of control devices, as well as books about motor controls, use different methods of showing the control circuit wiring. For example, in Figure 1-3B1, the control wiring from the start-stop pushbutton station runs to the actual connection points 1, 2, and 3. As the wiring diagrams become more complicated, the optional method shown in Figure 1-3B2 is frequently used to show the connection points for the start-stop pushbutton station. Here, in Figure 1-6, instead of running the control wires to the actual connection point, arrowed lines represent connections to be made by the installer.

Author's Comments:

- Many times you see plain lines (no arrows) with numbers to indicate connections to be made by the installer. We use both methods in this textbook.
- Many of the components and symbols used in ladder diagrams and wiring diagrams are the same. In order to make schematics easier to read, some manufacturers combine the two types of diagrams together. Some equipment comes with both ladder diagrams and wiring diagrams.

- Remember, ladder diagrams show electrical function and wiring diagrams show the actual components.

It's very common to find different styles of schematics combined in a single wiring diagram. The top part of the diagram in **Figure 1-7** is in the style of a connection diagram, while the style showing the start-stop station and coil is similar to a ladder diagram.

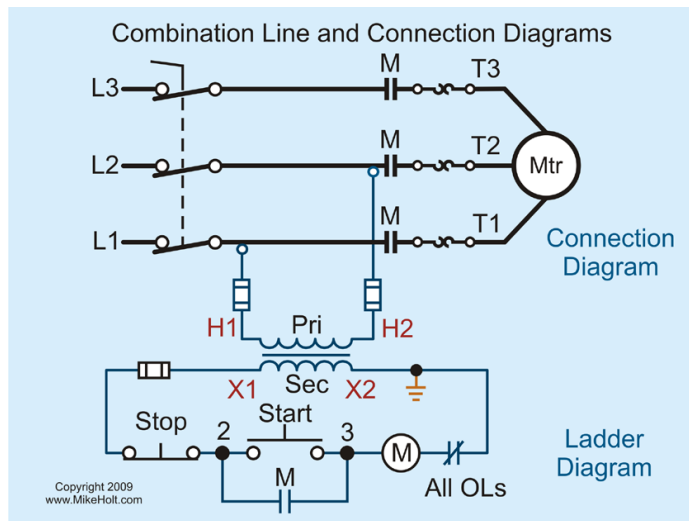

Figure 1-7

(3) Pictorial Diagrams (Figure 1-8)

Pictorial diagrams are often used in educational material and as exploded views or cut-away views in installation and maintenance literature. Pictorial diagrams help students see actual devices and components used in motor control circuits and how they relate to the symbols used in ladder diagrams and wiring diagrams. For example, the start pushbutton we mentioned earlier has wires run to the device that contains the set of contacts M in **Figure 1-4**, and to contact points 2 and 3 in **Figure 1-6**.

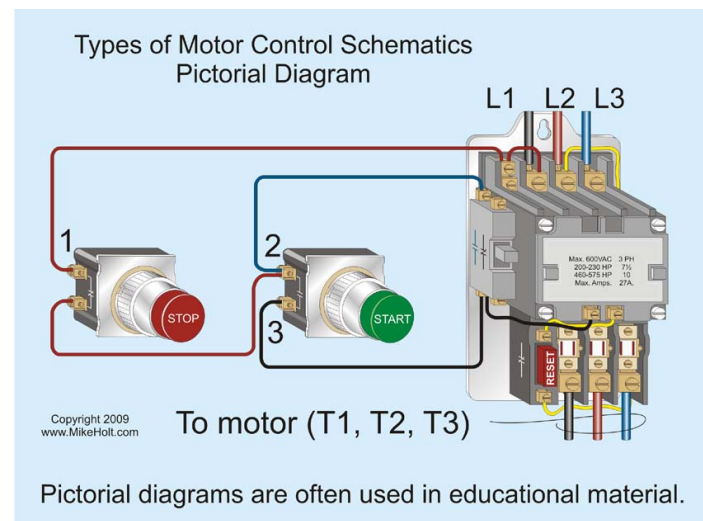

Figure 1-8

Author's Comments:

- Often a hand-drawn diagram of a control circuit constructed in the field helps in understanding how a circuit functions and how to make the necessary connections, especially during the learning process. **Figure 1-9** shows the hand-drawn version of the 3-wire start-stop control circuit shown in **Figure 1-3**. Notice that the stop pushbutton is in series with coil M, and that the start pushbutton is in parallel with M contacts 2-3. The entire control circuit in this example is in parallel between line 1 and line 2. These basic relationships can be found in many control circuits.
- The numbers in this diagram are simply for the aid of the reader and it don't imply that terminal 1 on one device should always be connected to terminal 1 on another device.

Once you understand the terminology and symbols involved in motor control circuit wiring, understanding how it works becomes easier and less intimidating.

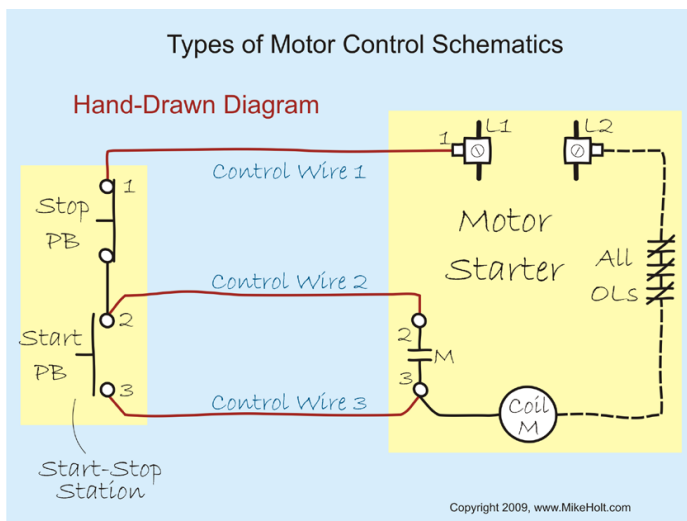

Figure 1-9

1.2 Motor Control Basics

The purpose of this textbook is to introduce the basics of motor controls. Many of the control circuits that are covered are standard control circuits used in many different applications. Each circuit can have several variations and optional devices in addition to those included in the schematics. This textbook won't teach you all of these control circuit variations, but will give you a basic understanding of motor controls, and how to read wiring diagrams and understand the sequences of operation.

When beginning this study of basic motor controls, remember that motor controls are basically different kinds of switches that turn things on and off, both manually and automatically. This may help you keep things in perspective.

There are many good books available for more advanced studies about this subject. Also check with the manufacturers of motor control equipment for educational material and standard motor control circuits.

Unit 1—Conclusion

This unit explained the basic concepts of motor controls, concentrating on how specialized electrical symbols, words, and line diagrams are used to convey information about motor control circuits. It provided an introduction to the following types of diagrams, which are used extensively throughout this textbook:

- Ladder diagrams (these are also called “line diagrams” or “elementary diagrams”).
- Connection diagrams (also called “wiring diagrams”).
- Pictorial diagrams.

Practice Questions

Unit 1—Practice Questions

Introduction

- A motor control circuit, for the most part, is simply a _____ and a motor.
 - motor
 - switch
 - feeder
 - magnet
- Many types of overload protectors operate on the relationship between _____.
 - heat and current
 - the neutral conductor and the earth
 - branch circuits and feeders
 - voltage and wattage
- Schematics show motors and control equipment in their “resting” or “shelf” state.
 - True
 - False
- Ladder diagrams are also known as _____.
 - line diagrams
 - elementary diagrams
 - pictorial diagrams
 - a or b
- _____ are used to represent the function of the control circuit and the associated devices, but don’t show the components of the control circuit in their actual positions.
 - Ladder diagrams
 - Connection diagrams
 - Wiring diagrams
 - Pictorial diagrams
- Connection diagrams are also called wiring diagrams.
 - True
 - False
- _____ are used mostly in educational material and as exploded views or cut-away views in installation and maintenance literature.
 - Ladder diagrams
 - Connection diagrams
 - Wiring diagrams
 - Pictorial diagrams
- The motor control circuit shown in **Figure 1–10** is a _____.
 - ladder diagram
 - connection diagram
 - wiring diagram
 - pictorial diagram

